



DRINK SYSTEMS S.p.a.

COSTRUZIONE DISTRIBUTORI DI BEVANDE - MANUFACTURER OF BEVERAGE DISPENSER

S.P.M. Drink Systems S.p.a. - 41057 Spilamberto (Mo) Italy - Via Panaro, 2/b

Tel. +39 059.789811 - Fax +39 059.781761

E-mail: info@spm-ice.it - Internet: www.spm-ice.it

Cod. Fisc. e Partita IVA 03195610369 - REA MO-366825

Cap. Soc. € 1000.000,00 i.v. - Foro Competente Modena - Cod. ident. CEE IT 03195610369

VFCB-G2 Operator's Manual

# VFCB-G2 (Visual Frozen Carbonated Beverage)

## Post-Mix Operator's Manual

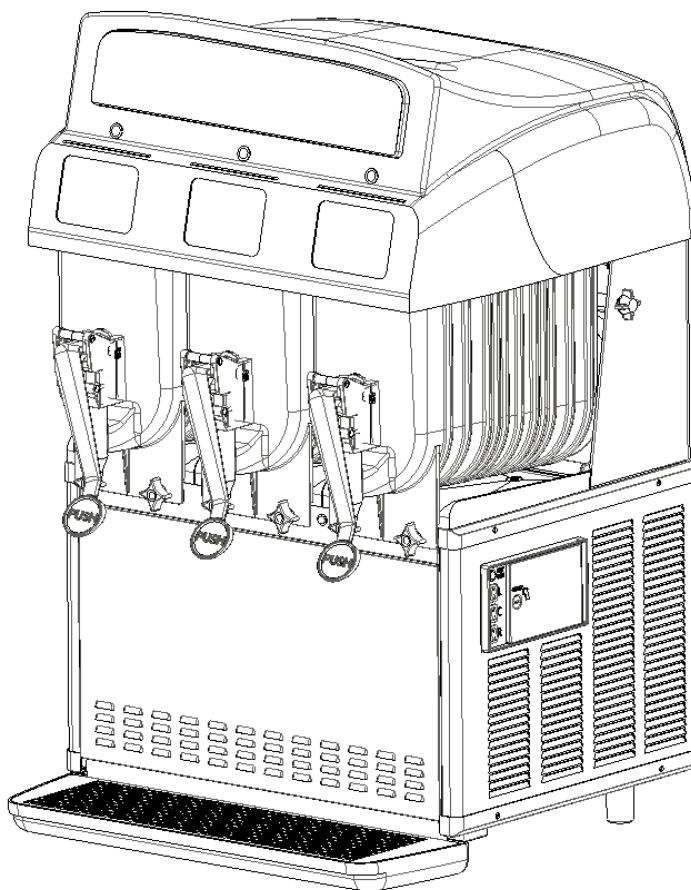

**Release Date: 01/03/11**  
**Publication Number: 1**  
**Revision: 1**  
**Pag. : 1/40**



DRINK SYSTEMS S.p.a.

COSTRUZIONE DISTRIBUTORI DI BEVANDE - MANUFACTURER OF BEVERAGE DISPENSER

S.P.M. Drink Systems S.p.a. - 41057 Spilamberto (Mo) Italy - Via Panaro, 2/b

Tel. +39 059.789811 - Fax +39 059.781761

E-mail: info@spm-ice.it - Internet: www.spm-ice.it

Cod. Fisc. e Partita IVA 03195610369 - REA MO-366825

Cap. Soc. € 1000.000,00 i.v. - Foro Competente Modena - Cod. ident. CEE IT 03195610369

**VFCB-G2 Operator's Manual**

## **VFCB POST-MIX AND PRE-MIX OPERATOR'S MANUAL**

Dear Customer,

We would like to congratulate you for choosing this high-quality product, that will certainly meet all your expectations.

We thank you for the preference reserved to our company and we invite you to carefully read the following instruction manual before machine's start up.

The products, technical information, and instructions contained in this manual are subject to change without notice. These instructions are not intended to cover all details or variations of the equipment, nor to provide for every possible contingency in the installation, operation or maintenance of this equipment. This manual assumes that the person(s) working on the equipment have been trained and are skilled in working with electrical, plumbing, pneumatic, and mechanical equipment. It is assumed that appropriate safety precautions are taken and that all local safety and construction requirements are being met, in addition to the information contained in this manual.

Published by:

SPM DRINK SYSTEMS S.p.a.

Via Panaro n° 2

41057 Spilamberto (MO)

Edition: 02/2011

Revision: 01

© 2011 – SPM Drink Systems

All copying rights are reserved to SPM DRINK SYSTEMS; copying, even partial, is illegal.

The descriptions and illustrations refer to the specific machine at issue. SPM Drink Systems reserves the right to modify at any time the equipment for mass production.

This manual:

- is integral part of the supply and must be carefully read, in order to be properly used, in compliance with the essential safety requirements;
- has been drafted by following the dispositions 2006/42/CE and reports the technical information that are necessary to correctly run all the procedures, under safety conditions;
- must be carefully kept (protected by a transparent, watertight wrapping, in order to avoid any damage) and must go with the machine during its life, including potential changes of ownership. In case of loss or damage, it's possible to ask for a copy to SPM DRINK SYSTEMS, pointing out the information stated on the identification label.

SPM DRINK SYSTEMS declines all responsibility for a wrong usage of the machine and/or damages caused by operations not provided for in this manual.

**Release Date: 01/03/11**

**Publication Number: 1**

**Revision: 1**

**Pag. : 2/40**



DRINK SYSTEMS s.p.a.

COSTRUZIONE DISTRIBUTORI DI BEVANDE - MANUFACTURER OF BEVERAGE DISPENSER

S.P.M. Drink Systems S.p.a. - 41057 Spilamberto (Mo) Italy - Via Panaro, 2/b  
Tel. +39 059.789811 - Fax +39 059.781761

E-mail: [info@spm-ice.it](mailto:info@spm-ice.it) - Internet: [www.spm-ice.it](http://www.spm-ice.it)

Cod. Fisc. e Partita IVA 03195610369 - REA MO-366825

Cap. Soc. € 1000.000,00 i.v. - Foro Competente Modena - Cod. ident. CEE IT 03195610369

## VFCB-G2 Operator's Manual

# TABLE OF CONTENTS

IMPORTANT WARNINGS AND ADVICES .....	4
TECHNICAL DATA .....	5
TRANSPORTATION and LIFTING INDICATIONS .....	6
INSTALLATION.....	7
CONNECTING THE ELECTRICITY MAINS .....	8
TAP KIT INSTRUCTION.....	9
CONNECTION DIAGRAMS .....	10
BOWL LOADING OPERATIONS .....	12
OPERATING AND SETTING .....	14
CONSISTENCY ADJUSTMENT.....	18
SIX MONTHLY CLEANING AND SANITATION.....	19
SPECIAL MAINTENANCE .....	23
AUTOFILL SYSTEM and PRESSURE MANAGEMENT.....	27
WIRING DIAGRAM.....	30
TROUBLESHOOTING.....	33

**Release Date: 01/03/11**

**Publication Number: 1**

**Revision: 1**

**Pag. : 3/40**

## IMPORTANT WARNINGS AND ADVICES

This instruction manual represents an integral part of the equipment and must be kept readily available for use. Read the warnings contained herein carefully before installing and using this equipment. In addition to offering information concerning routine maintenance for the ice slush drinks machine and technical back-up for troubleshooting, this manual aims to help the user make the most of the machine's potential, adapting it to suit the specific needs of the various countries it will be used in. Modifications or attempts to modify the equipment will not only result in the forfeiture of the guarantee, but are also extremely dangerous.

The maintenance operations must be carried out by qualified professionals. Never attempt to repair the machine yourselves as the intervention of non-qualified persons, as well as being hazardous, could also lead to serious damage to the machine.

Unless otherwise stated, this manual is addressed to operators (staff members who uses the equipment on a daily basis) and to servicemen (staff members qualified to carry out the installation and/or maintenance). The parts of the manual addressed only to servicemen are pointed out accordingly. Please read carefully the warnings listed here below before installation and start-up of the equipment.

This equipment has been designed to produce slushes, sorbets and similar products.

Upon receipt of the equipment, make sure that its part number matches the one specified in the order, which can be found on all the delivery documents.

This equipment is exclusively destined to the purpose for which it was designed. The manufacturer cannot be held responsible for any damage due to improper use.

This equipment is not intended for use by persons (including children) with reduced physical, sensory or mental capabilities, or lack of experience and knowledge, without supervision or instruction concerning its use by a person responsible for their safety. Children should be supervised to ensure that they do not play with the machine.

This equipment is not suitable for outdoor use. This machine is not suitable for installation in locations where water jets are used. This equipment must be installed in places where it can be controlled by qualified staff.

### **!WARNING!**

**Before starting up the machine it's necessary to perform all the cleaning and sanitation procedures.**



### **Warning**

The CO2 supply must be turned off before shutting off the water supply.

**Failure to comply could result in personal injury or damage to the equipment.**

## TECHNICAL DATA

### PLATE DATA

The voltage and the frequency are indicated on the serial number plate, located behind the drip tray and the right hand side near the controls.

Machine	Bowl n°	Volt	Hertz	Ampere
VFCB POST MIX	2	115	60	11.8
VFCB POST MIX	3	115	60	15.9

**IMPORTANT: This machine is intended for use at a maximum ambient temperature of 32°C (90°F).**

Dimensions and weight:

#### VFCB2-G2

- Height: 99 cm
- Width: 41 cm
- Depth: 68 cm
- Weight: approx 81 kg

#### VFCB3-G2

- Height: 99 cm
- Width: 60 cm
- Depth: 68 cm
- Weight: approx 113 kg

In the event of breakdown:

In most cases, any technical problem can be settled with slight interventions (please see the troubleshooting guide at the end of this manual); we therefore recommend you to carefully read this handbook before contacting the manufacturer or service centre.

Disposal



**Caution**

All the parts of the packaging must be kept beyond the range of children, as they might represent a potential safety/health risk.

#### **Important**

In respect of the environment, please dispose the packaging as illustrated.



This symbol:  means that the machine cannot be disposed as common waste. It must be handled in compliance with the provisions of European directive 2003/108/CE (Waste Electrical and Electronic Devices - WEEE) and the resulting national legislation, in order to prevent any potential damage to the environment and to create health risks.

In order to correctly dispose of the device, please contact the distributor from which you purchased it or our after-sales service.

**Release Date: 01/03/11**

**Publication Number: 1**

**Revision: 1**

**Pag. : 5/40**

## TRANSPORTATION and LIFTING INDICATIONS

To prevent the oil contained in the compressor from flowing out into the cooling circuit, the equipment must be transported, stored, and handled in a vertical position, as per the indications given on the packing.

If the device is accidentally or intentionally (for transportation reasons) kept in any other position, it must be set again in the correct position at least one hour before start-up procedures, in order to let the oil flow back into the compressor.

The wooden pallet, equipped with housing for the lifting forks, allows the packed equipment to be moved using normal handling and hoisting means.



Never lift the machine alone, but always seek the assistance of another operator.

To prevent and avoid any damage to the machine, all loading and unloading operations should be carried out with special care. The equipment can be lifted, with either a manual or engine-powered lifting truck, by positioning the forks in the base section of the unit.

### **The following operations should always be avoided:**

- to turn upside down the machine;
- to drag the machine with ropes or others;
- to lift the machine with slings or ropes
- to shake or rattle the machine and its packaging.

The machine must be stored in a dry place with temperatures from 0°C to 40 °C. No more than 2 machines should be stacked on top of each other, taking care to maintain the vertical position, as shown by the arrows on the carton.

## INSTALLATION

### !WARNING!

The installation and subsequent servicing operations must be carried out by skilled members who have been trained to use the device and in compliance with the regulations in force.

a) Release the equipment from the packing, then slide it off upwards (see fig. 1); preserve the packaging in order to reuse it for winter storage and make sure the machine is in perfect condition.

### **!CAUTION!**

**All the pieces of packing must be kept out of reach of children as they represent potential hazards.**

b) Checking the machine identification after removing the packing, you must check that the equipment you have received is exactly as you ordered, making sure the specifications indicated on the invoice or the delivery note are identical to those on the data plate.

c) Equipment accessories

On opening the packing you will find the following accessories:

- this instruction manual;
- 1 tube of Vaseline to be used for the maintenance machine the requires;
- 1 bag for each bowls, each one containing a tap kit;
- 1 drip tray;
- 1 suction gasket for each bowl.

d) Positioning - the machine has to be installed in level with horizontal plane on a sturdy, flat surface; make sure the machine's bodywork is well ventilated (20cm (8") all around at least ) and do not install it near heat sources.

**We recommend you keep the room temperature at between 68°F (20°C) and 90°F (32°C).**

e) Check that the power mains voltage meets the specifications on the equipment identification plate and that the output available meets the device's power requirements. Fit the plug into an earthed socket and remove all multiple adaptors.

FOR FURTHER PRECAUTIONS, READ THE SECTION "CONNECTING THE ELECTRICITY MAINS" CAREFULLY.

f) The installation must be carried out in accordance with the manufacturer's instructions. Failure to comply with the positioning and installation instructions may impair the machine's operation.

### !Important!

You are legally required to provide a suitable grounding system for the equipment. Before carrying out any cleaning and/or special maintenance on the device, make sure it is disconnected from the mains by unplugging it.

In the event of a breakdown or malfunctioning, switch off the device and remove the plug.

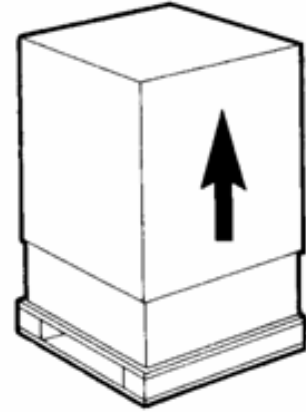

Fig. 1

## CONNECTING THE ELECTRICITY MAINS

Before inserting the plug into the mains socket for your own safety you must take careful note of the following precautions.

- The machine's electrical system can only be considered safe when it is connected correctly to an earthing system, as provided for by the national safety regulations. The manufacturer cannot be held responsible for any damages that may be caused by failure to earth the system.

- For the system to be installed correctly and safely, it is essential to provide a suitable socket which complies with the national safety standards in force (see Fig. 2).

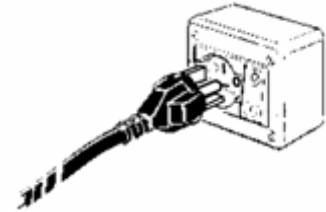

Fig. 2

- Check the length of the power supply cable to make sure it is not being crushed, do not use extension cables or multiple adaptors and, to remove the plug, first turn off the switch, then hold the plug tightly and pull gently.

- Do not obstruct the ventilation and the heat dissipation grids as bad airing, in addition to reducing the output and causing bad functioning, could also lead to serious damage to the equipment.

- Always verify electrical specifications on the data plate of each machine. Data plate specifications always replace the information of this manual.

**IMPORTANT: If the power supply cable is damaged, it must be replaced by qualified persons only, to prevent any possible risks.**

## TAP KIT INSTRUCTION

On opening the packing you will find one bag for each bowls, each one containing a tap kit; in order to assemble it on the unit proceed as follow:

- Insert the tap inside its seating, remembering to smear both its seating in the bowl and the seals with Vaseline.
- Assemble the handle blocking system as described below (fig.16).

The new system consists of two symmetric parts that have to be assembled around the tap as described by the image below.

### **!CAUTION!**

IN ORDER TO OBTAIN A PERFECT MATCHING BETWEEN THE LEFT AND THE RIGHT PART OF THE BLOCKAGE SYSTEM, PLEASE DON'T TIGHTEN EACH M4X35 SCREW ALL AT ONCE UNTIL POSSIBLE BUT MANUALLY TIGHTEN EACH ONE A BIT AND THEN THE OTHERS, ONE AFTER ONE, UNTIL ALL THE SYSTEM WILL BE COMPLETELY AND PERFECTLY CLOSED AROUND THE TAP.

FAILURE TO DO SO COULD PREVENT THE GOOD MATCHING BETWEEN THE TWO PARTS.

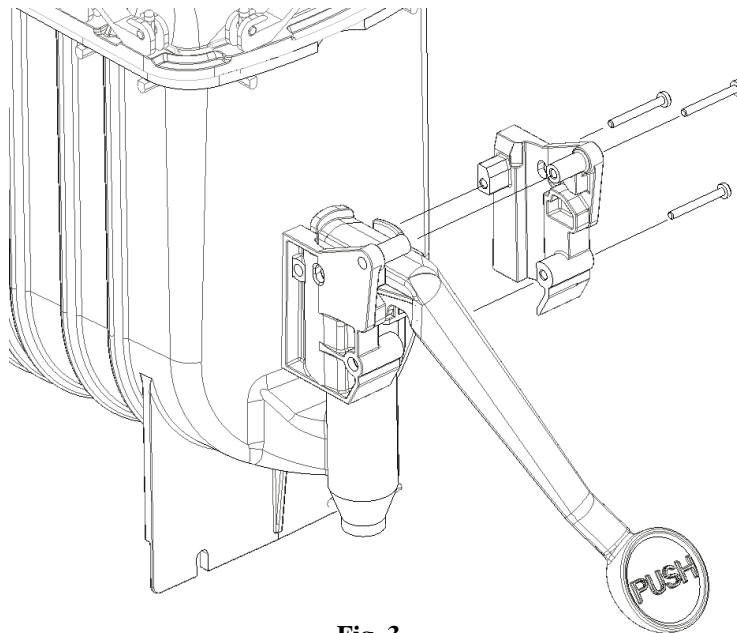

**Fig. 3**

## CONNECTION DIAGRAMS



**Warning**  
 The CO2 supply must be turned off before shutting off the water supply.  
**Failure to comply could result in personal injury or damage to the equipment.**

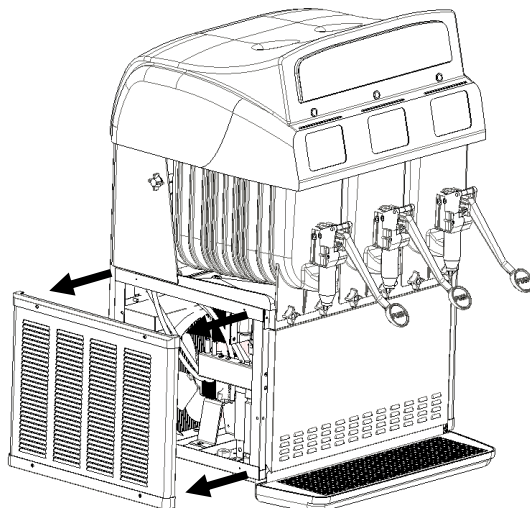

Fig. 4

### Connection:

After removing the left side panel as illustrated in fig.3, proceed by connecting the unit pipes L, C, R, W and CO2 indicated in fig.4 to the existing post-mix system using quick couplings. Use the inlet holes (fig.4) to insert the existing post-mix system pipes inside the unit frame.

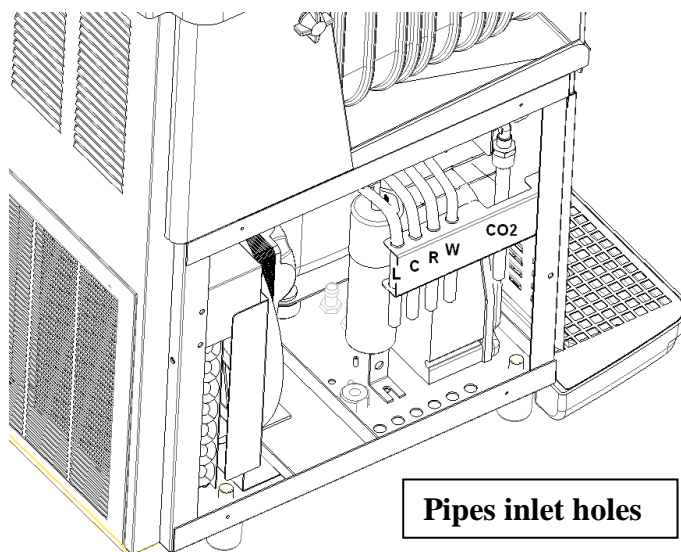

Fig. 5

The diagram in fig.5 shows the general features for the connection between the VFCB POST-MIX to an existing post-mix system.

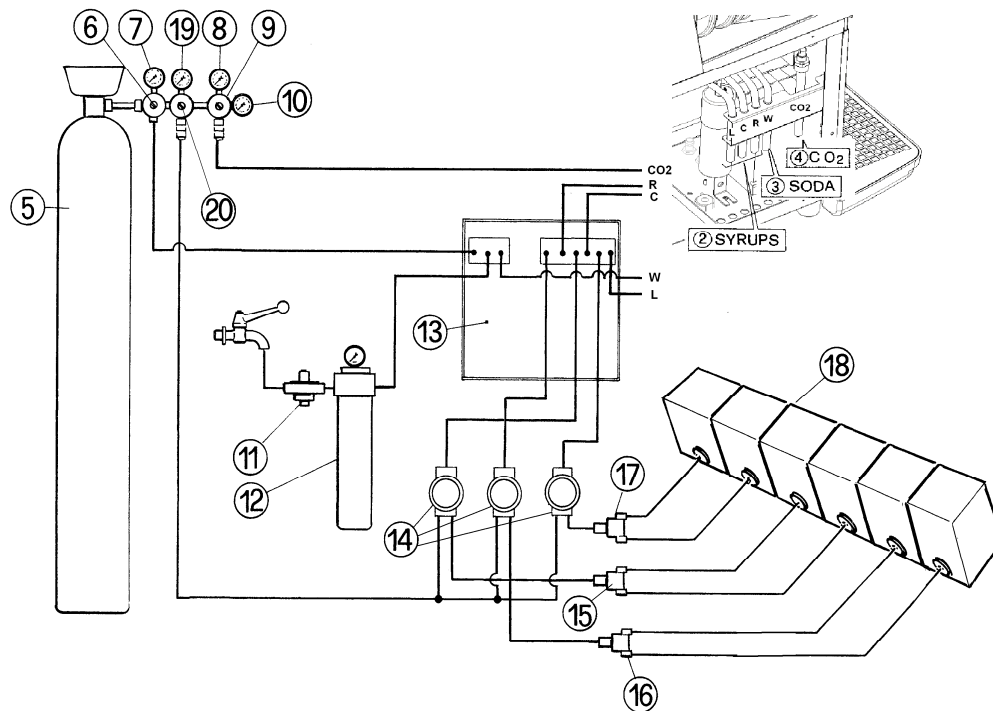

Fig. 6

**Description:**

- (L) Left bowl syrup inlet
- (C) Central bowl syrup inlet
- (R) Right bowl syrup inlet
- (W) Soda Water inlet
- (CO2) CO2 inlet
- (2) Syrups inlet
- (3) Soda water inlet
- (4) Inlet for CO2 (recommended pressure 35 PSI – 2.4 Bar)
- (5) CO2 gas cylinder
- (6) Operating pressure reducing valve for carbonation unit
- (7) Carbonation unit operating pressure gauge
- (8) Unit Operating pressure gauges
- (9) Pressure reducing valve
- (10) Gas cylinder operating pressure gauge
- (11) Water pressure reducing valve
- (12) Filter
- (13) Carbonation unit and optional pre-cooling unit
- (14) Syrup pumps
- (15) Bag-in-box exchanger
- (16) Bag-in-box exchanger
- (17) Bag-in-box exchanger
- (18) Bag-in-box
- (19) BIB Operating pressure gauges
- (20) Pressure reducing valve

**Release Date: 01/03/11**

**Publication Number: 1**

**Revision: 1**

**Pag. : 11/40**

## BOWL LOADING OPERATIONS

### VFCB (POST-MIX)

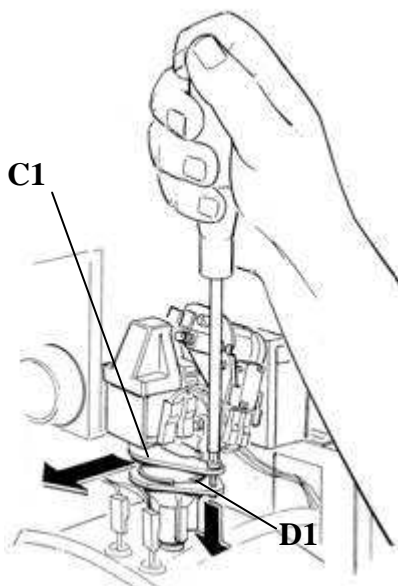

Fig. 7

- Make sure the power cable is disconnected from the mains;
- Loosen the valve flanges screws as indicated in the fig.4 without disconnecting them from the inferior flange;
- Remove the superior flange C1 as indicated by the arrow in the fig.6;
- Leave the inferior flange D1 on the bowl surface, it will be easier to reassemble it after the brixing procedures.

• Using an 8 mm socket wrench E1, loosen the nut that holds the post-mix valve D1 (fig.7).

• Lift the post mix valve D1 up slightly and turn it towards the outside. Leaving nozzle F1 and coupling attached to the bowl (fig.7).

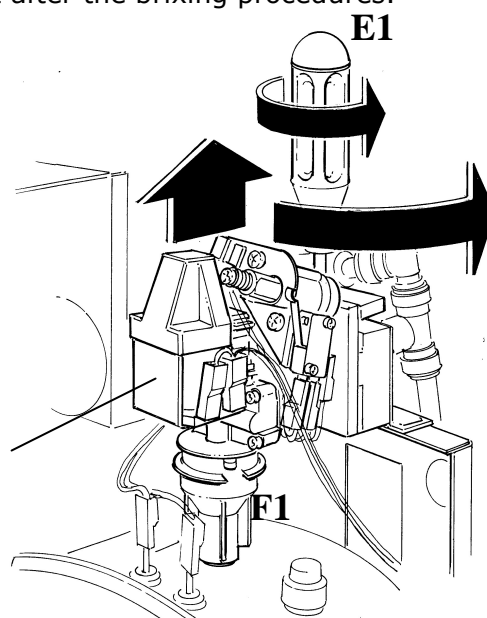

Fig. 8

• Now rotate the valve assembly 90 degrees and slide to the outside of the machine. Tighten the 8mm nut using a socket wrench E1 (fig. 8).

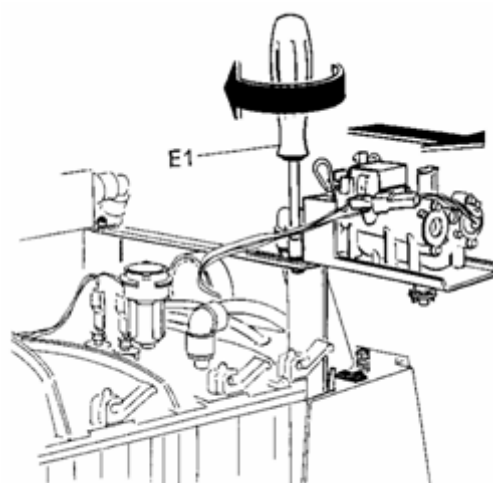

Fig. 9

- Assemble the valve plate A1 and the black knob B1 (you can find them inside the machine package) as indicate in the fig.9;
- If you need to do the brixing procedures using the calibrator/separator you have to assemble it instead the black knob;
- Checking and adjusting the water flow is most easily done by first disconnecting the syrup bib.

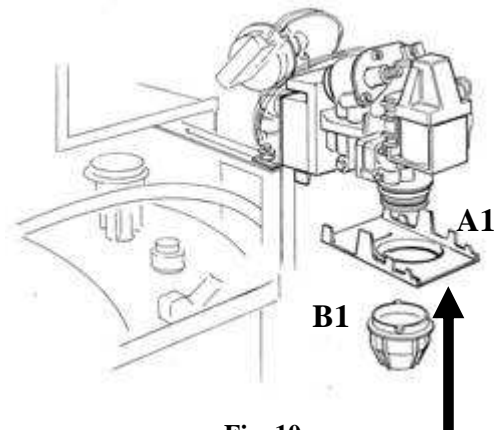

Fig. 10

- Connect the unit plug to the electricity mains and open the command board plastic door Z (fig.10); if the control board box is open, each switch T controls the correspondent post-mix valve to carry out the brix operation (this is possible only if both water and syrup are present). This operation is possible only on one valve at the time.

NOTE: when the box is open, the compressor, the fan, the auger motors and the refrigerating system valves are off.

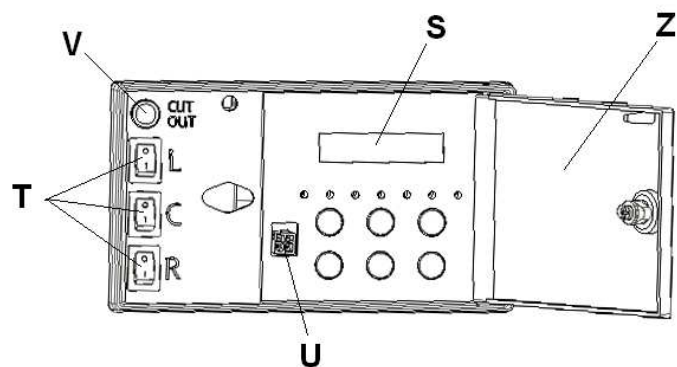

Fig. 11

- Press the bowl related switch T (fig.10) in order to dispense product from the correspondent mixing valve:
  - L refers to the left bowl;
  - C refers to the central bowl;
  - R refers to the right bowl.

- If necessary apply the calibrator/separator relative measuring cup H1 and push the related button on the command panel until both the soda water and the syrup run into the measuring cup separately (fig.11).

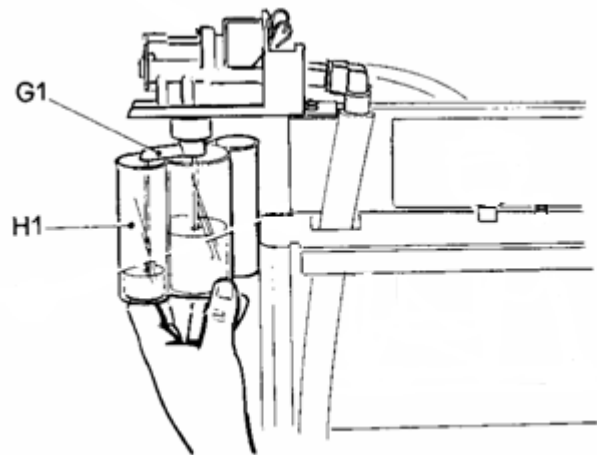

Fig. 12

- Adjust the water flow to the minimum level in order to reduce the inlet pressure. Turn the water adjustment screw on the flow control counter clockwise until the minimum position to decrease water flow (clockwise to increase it).

- Dispense product into a cup or into the measuring cup by depressing the switch on the panel. Check brix using a refractometer or the measuring cup. The brix should be set to 13% ± 1%. To increase the brix adjust the syrup adjustment screw on the valve clockwise to increase syrup flow or counter clockwise to decrease syrup flow.

**CAUTION: Do not turn the syrup flow control counter clockwise to far .**

**Release Date: 01/03/11**

**Publication Number: 1**

**Revision: 1**

**Pag. : 13/40**

- When the brix has been set to specification, reposition the valve to its original setting and tighten retaining nuts.
- Repeat this operation for each bowl.
- Once the adjustments have been completed for each bowl, close the plastic door and switch ON the three bowl switches.
- The mixing motors will be turned on, all the bowls will fill until the level sensor is activated and the unit will start working as set.

NOTE: During initial filling it is normal for some foaming to take place. The bowl level management will adjust as the product freezes & the foam will dissipate.

## OPERATING AND SETTING

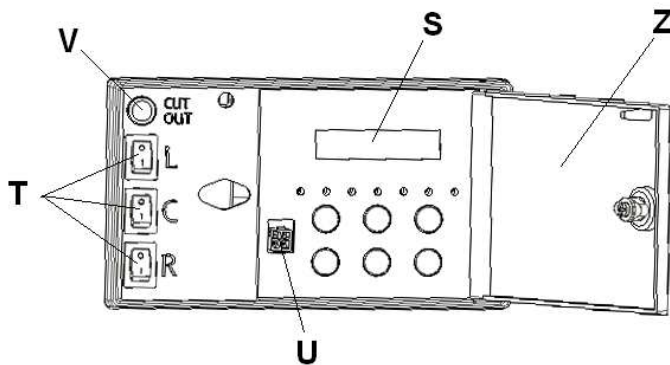

### AUTOMATIC OPERATING

The VFCB-G2 units have been designed to completely operate in an automatic way; when the control panel plastic door Z is CLOSED and one of the three switches T is switched ON, the automatic functioning starts for the related bowl with the set parameters.

### CUT OUT PRESSURE SWITCH ALARM

These units are equipped with a security pressure switch that will shut off the refrigerating system if the internal pressure is too high; when this occurs the CUT OUT LED V is switched ON without blinking to alert the operator of this condition. When this alarm activates the condenser temperature probe is probably malfunctioning so, turn off all switches, check it and then determine the condition (see "Filter Cleaning" Alarm Section for Conditions and Corrective Actions). In order to switch off this alarm it will be necessary to manually switch off the pressure switch (red button under the unit see fig.12).

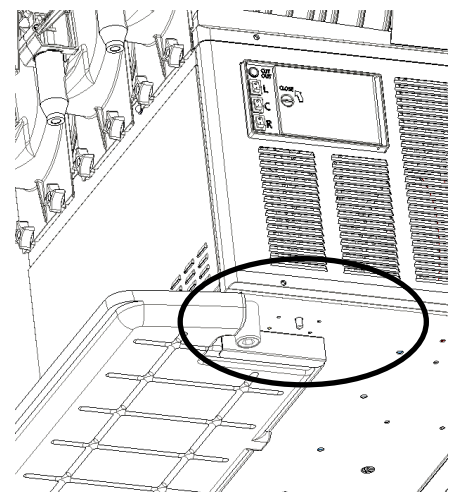
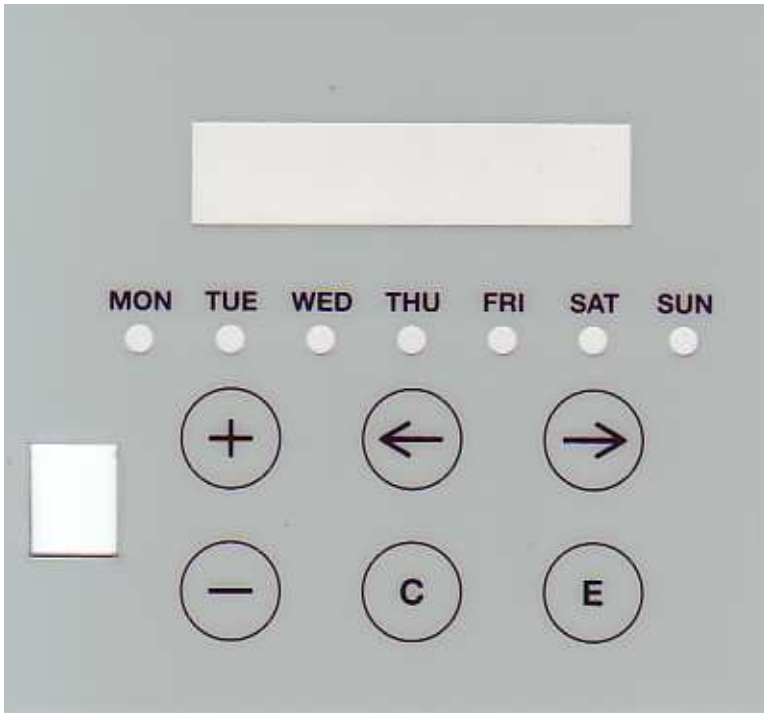

Fig. 13

## AUTOMATIC OPERATING SETUP

In order to set the automatic operating parameters and the brix value, the control panel plastic door Z has to be OPENED.



### Description:

**+** : INCREASE

**-** : DECREASE

**<-** : SHIFT LEFT

**->** : SHIFT RIGHT

**C** : CANCEL

**E** : ENTER

Once opened the control box, the display S will show the message  
**SPM term V.x.x** (firmware version of the control unit), and  
**press any key...** (at first startup of the unit) or  
**VFCB3-G2 V.x.x** (firmware version of the mainboard).

Pressing one of the six buttons will enter the setting/verify procedure. The first message is:

### **SELECT FUNCTION TIME SETUP**

With the shift right and shift left arrows is it possible to move along the select function menu:

- Time setup;
- Scheduler setup;
- Select Language.

Pressing the enter button E it is possible to enter inside each of these functions; pressing the cancel button C it is possible to return a level behind.



DRINK SYSTEMS s.p.a.

COSTRUZIONE DISTRIBUTORI DI BEVANDE - MANUFACTURER OF BEVERAGE DISPENSER

S.P.M. Drink Systems S.p.a. - 41057 Spilamberto (Mo) Italy - Via Panaro, 2/b  
Tel. +39 059.789811 - Fax +39 059.781761

E-mail: info@spm-ice.it - Internet: www.spm-ice.it

Cod. Fisc. e Partita IVA 03195610369 - REA MO-366825

Cap. Soc. € 1000.000,00 i.v. - Foro Competente Modena - Cod. ident. CEE IT 03195610369

## VFCB-G2 Operator's Manual

### TIME SETUP

After pressing the E button in order to enter this menu, the message is:

#### **Actual time**

**hh:mm am/pm mm/dd/yy**

**With the actual day LED on.**

Press the enter button E in order to modify the time and date or the C button to exit with the settings unchanged.

After pressing the E button the changing blinking cursor appears. Using the two shift arrows it is possible to move the cursor and using the + and - buttons it is possible to modify the numbers value and the am/pm mode.

After modifying the time as desired, pushing once again the right shift with the cursor at the right side of the display, the actual day LED will start blinking. At this point it is possible to move along the days with the right and left arrows in order to modify the day. Once the right one is blinking, pushing the enter button will save the time and date. Press any key to return to the first menu.

Push the C button at any level to exit with the settings unchanged.

### SCHEDULER SETUP

This submenu will allow to set or view the freezing and the defrost modality for each day of the week.

After pressing the E button in order to enter this menu, the first message will be:

#### **Start operation**

**at hh:mm am/pm**

With the Monday LED turned on.

Use the left and right arrows to move to the next or previous timings to verify the actual setting of the scheduler.

The next time setting is:

#### **Start defrost**

**at hh:mm am/pm** with the Monday LED turned on.

Pressing the right shift once again you will see:

#### **Start operation**

**at hh:mm** with the Tuesday LED turned on, and so on.

In this way it is possible to set or view the freezing and the defrost starting time for each day of the week.

Press the E button in order to modify each time. You'll see the cursor blinking on the first time number.

Move along the time numbers with the right and left arrows, modify the time numbers and the am/pm mode with the + and the - buttons and press again E to fix the changes.

Press the C button to exit with the settings unchanged.

**Release Date: 01/03/11**

**Publication Number: 1**

**Revision: 1**

**Pag. : 16/40**



DRINK SYSTEMS S.p.a.

COSTRUZIONE DISTRIBUTORI DI BEVANDE - MANUFACTURER OF BEVERAGE DISPENSER

S.P.M. Drink Systems S.p.a. - 41057 Spilamberto (Mo) Italy - Via Panaro, 2/b

Tel. +39 059.789811 - Fax +39 059.781761

E-mail: info@spm-ice.it - Internet: www.spm-ice.it

Cod. Fisc. e Partita IVA 03195610369 - REA MO-366825

Cap. Soc. € 1000.000,00 i.v. - Foro Competente Modena - Cod. ident. CEE IT 03195610369

## VFCB-G2 Operator's Manual

After setting or reading the Sunday start defrost time, pressing the right shift button you will see:

### Select Mode

#### Automatic mode (or Manual mode)

Press the right or left arrows to select between the two modes of operation.

By selecting the "Automatic mode" the unit will automatically work with the freeze/defrost time scheduler set for each day of the week; on the contrary, by selecting the "Manual mode", once the door is closed and the switches are activated, the unit will work in freeze mode until the switches are turned in the OFF position.

**Please note that the merchandizing light inside the cover will be ON only during the freeze mode while it will be switched OFF during the defrost one.**

Press the E button to save all the week scheduling and the operation mode or the C button to exit with the settings unchanged.

Press any key to return to the first menu.

### SELECT LANGUAGE

After pressing the E button in order to enter this menu, the message is

#### Select Language

#### English (or Italiano)

Press the right or left arrows to select between the two languages.

Press the E button to save the changes or the C button to exit with the settings unchanged.

Please note that, selecting the ENGLISH language, the hours mode will be automatically switched from 24h to 12h visualization.

### TROUBLESHOOTING AND SUGGESTIONS

Before closing the control box press the C button in order to set the control unit in idle mode.

If the display shows the message:

**COMMUNIC. ERROR!**

**CHECK MAINBOARD**

there is a problem in communication between the control unit and the mainboard. The unit will continue to work correctly but you will not be able to modify the settings. Call assistance to solve the problem.

**Release Date: 01/03/11**

**Publication Number: 1**

**Revision: 1**

**Pag. : 17/40**

## CONSISTENCY ADJUSTMENT

1. To dispense product, place the cup beneath the tap and push the lever very gently (fig. 13).

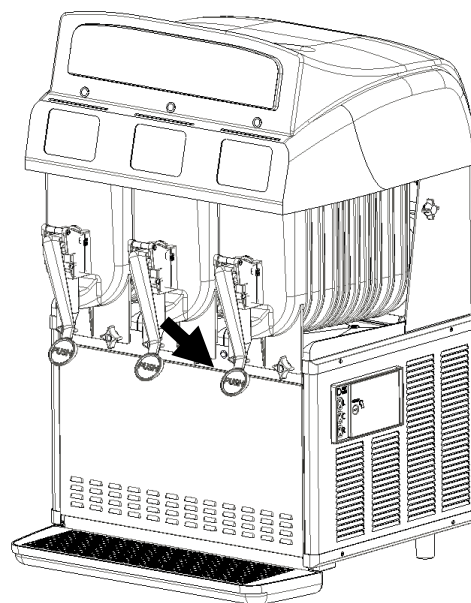

Fig. 14

2. Adjusting the consistency:
  - Remove the cover fig. 14;
  - Remove the rear panel of the unit by loosening the fixing screws;
  - To vary the consistency of the ice slush, turn the knob as shown in fig. 15. Turning the knob counter-clockwise will increase viscosity (make the product denser). Turning the knob clockwise will decrease viscosity (make the product less dense).

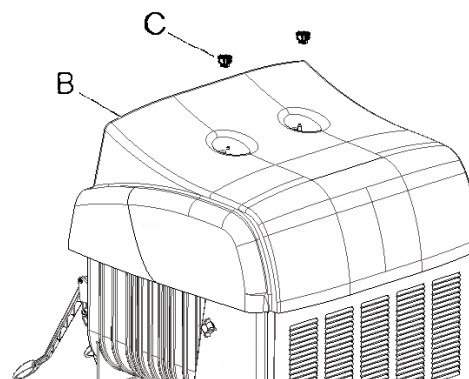

Fig. 15

**!WARNING!**  
 This device only changes the consistency of the ice slush dispensed, it does not effect the cooling temperature.

An indicator gauge for reference is located on the gearmotor plastic cover side under the consistency knob.

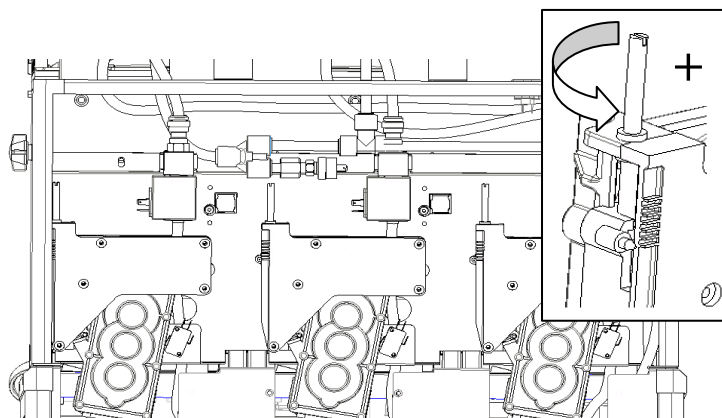

Fig. 16

## SIX MONTHLY CLEANING AND SANITATION

### OPERATIONS:

**ATTENTION: The cleaning operations must be performed with the machine disconnected from the power supply.**

1. Empty the bowl of any remaining product, switch off the bowl switches and disconnect the power cable from the mains.
2. Remove the cover B (fig.17).

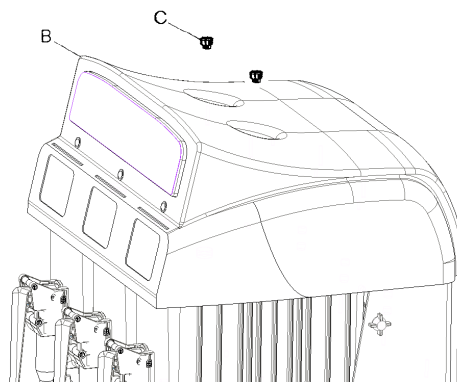

Fig. 17

3. Extract the quick couplings and the pressure switch (see part number 11 in figure 40) as illustrated in fig.18.

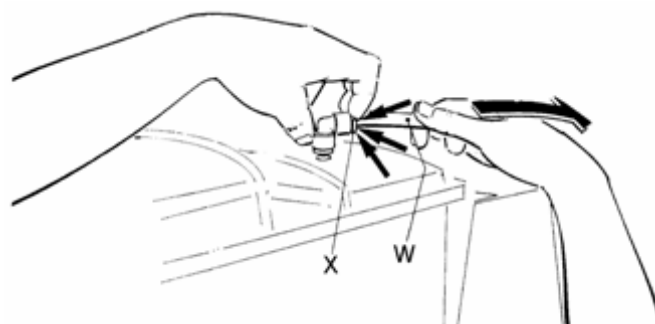

Fig. 18

4. Disconnect the probe fastenings E2 (fig.19).
5. Now rotate the valve assembly 90 degrees and slide to the outside of the machine. Tighten the 8mm nut using a socket wrench E1 (fig.19).

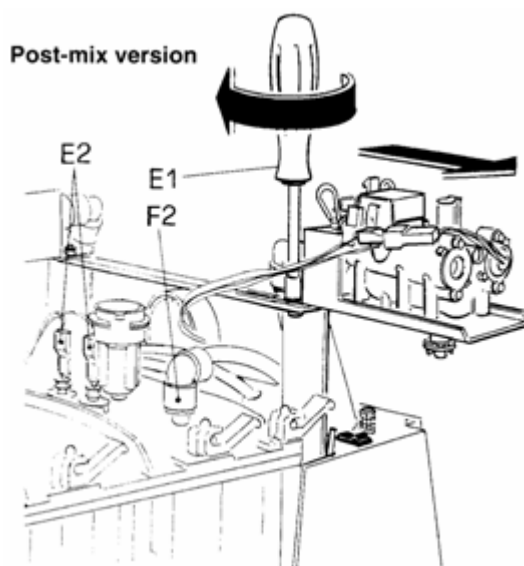

Fig. 19

- Pull the lock pin/safety pin Y upwards, if the machine version is without pin, unscrew one of the two locking knobs Y1 (fig.20).



Fig. 20

- Slide the locking bar Z (fig.21) outwards so that the bowls are fully released.



Fig. 21

- Lift the bowl lid cap lever (fig.22), remove the cap, unscrew the knobs A1 (in this way the bowls can be lowered slightly), open the tap to remove any remaining liquids and then extract the bowl from its seating, pulling it outwards (fig.22).

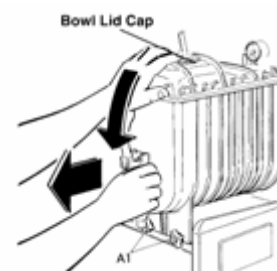

Fig. 22

- Remove the handle blocking system by loosening the three fixing screws (fig.23).

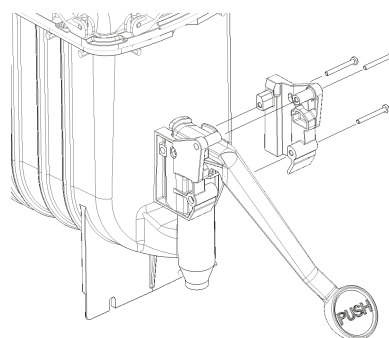

Fig. 23

- Remove the tap from its seating, pressing the two clamping wings at the same time (fig.24) and pushing upwards.

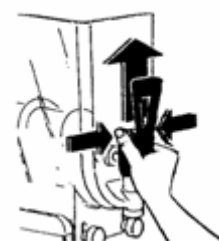

Fig. 24

11. Dismount the tap, holding the body R pressed downwards, then slide the lever L out of its seating (fig.25). Wash all the parts thoroughly with hot water and washing-up liquid, rinse them well, and proceed to remount them.

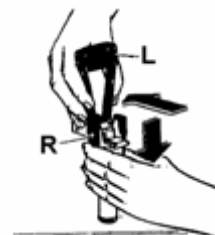

Fig. 25

12. Separate the bowl from its cover, releasing the fastening D1 by pulling them upwards as shown in fig.26.

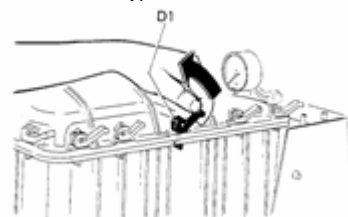

Fig. 26

13. Wash the bowl lid cap (fig.27), the bowl and its cover carefully with water and washing-up liquid, rinse them well, and proceed to remount them, making sure the sealing strip E1 is positioned correctly between the cover and the bowl. To guarantee the seal, the rounded part of the said sealing strip (as shown in fig.27) must be facing the cover.

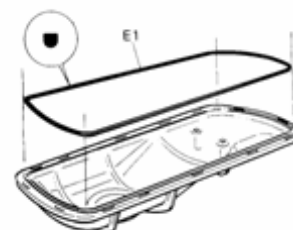

Fig. 27

14. Unscrew the fastening knob F1 clockwise as the direction indicated by the arrow (threading to the left) and proceed by extracting the spiral scraper G1 and the seals H1 and I1. Clean the individual parts thoroughly (fig.28).

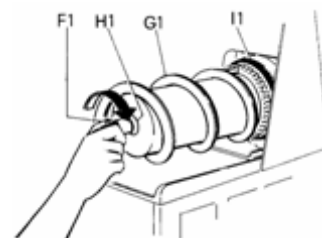

Fig. 28

15. Clean the drip tray J1 and the evaporator K1 well (fig.29).  
**CAUTION: Do not wash any components in a dishwasher.**

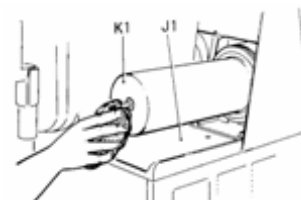
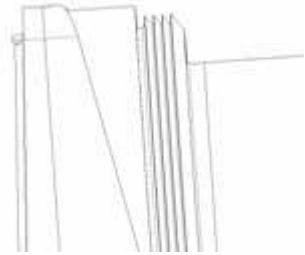

Fig. 29

16. Proceed to remount the mixing unit as follows:

- dampen the sealing strip I1 and insert it into its seating in the correct position (fig.30);
- apply a copious amount of Vaseline (supplied with the machine) to the suction cup seal H1 (on the part that comes into contact with the evaporator K1) and insert it in its spiral seating (fig.28);
- remount the spiral scraper G1 (fig.28);
- fasten all the components in place by screwing the knob F1 counter-clockwise (fig.28).



**Fig. 30**

17. Remount the bowl by pushing it into its seating (fig.31).

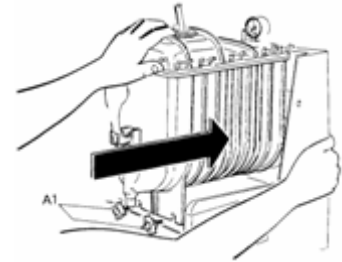

**Fig. 31**

18. Proceed to fasten the bowl in place by tightening the knobs A1 (fig.31) and the locking bar Z (fig.21).

19. Remount the tap, remembering to smear both its seating in the bowl and the seals J with Vaseline (fig.32).

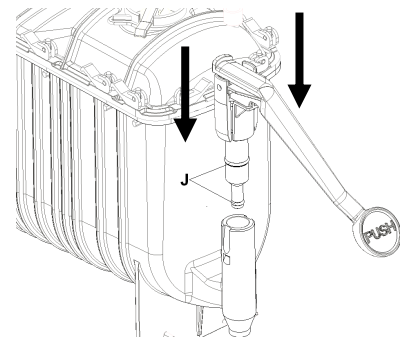

**Fig. 32**

20. Dismount the drip tray by slightly pulling it outwards (fig.33). Wash all the parts carefully and proceed to reassemble it by following the aforesaid operations.

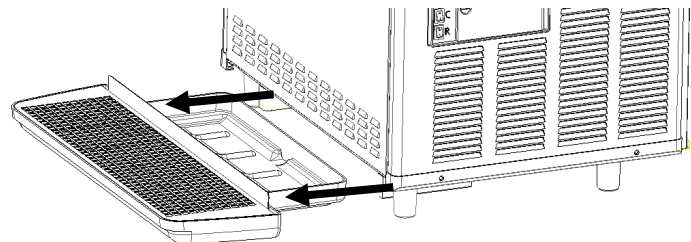

**Fig. 33**

**CAUTION: Since the CO2 system is discharging directly inside the drip tray, it is very important to empty it frequently.**

NOTE:

"Six monthly" cleaning procedure is the standard time and it is suitable for the most of the products, but the cleaning procedure depends on the kind of product used. If the product used is a made of milk or 100% fruit plus sugar, for example, "Three monthly" cleaning procedure is request. In case of doubt please contact the assistance or do the "Three monthly" cleaning procedure.

**Release Date: 01/03/11**

**Publication Number: 1**

**Revision: 1**

**Pag. : 22/40**

## SPECIAL MAINTENANCE

**WARNING:** You are reminded that all the operations described below must be carried out with the machine switched off and the power cable disconnected.

### GEARMOTORS REPLACEMENT

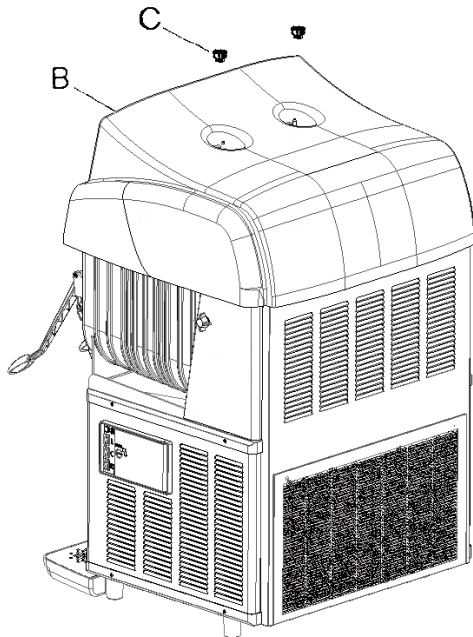

Fig. 34

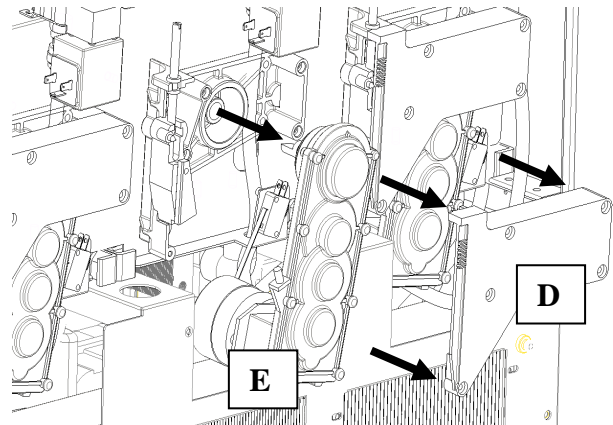

Fig. 35

If it is necessary to replace a gear motor, proceed as follows:

- Disconnect the unit from the power supply;
- Unscrew the fixing knobs C and remove the cover B (fig.34);
- Remove the gearmotor plastic cover fixing screws and take away the cover D by pulling it outward as showed in fig.35;
- Unplug the gearmotor E and remove it by gently pulling it outward as showed in fig.35.

## CONDENSER FILTER CLEANING

**ATTENTION: To guarantee the cooling system a good performance level, the routine cleaning of the condenser filter is essential.**

A luminous signal from the **condenser LED** indicated in fig.36, will warn the operator when the filter is clogged and has to be cleaned before the machine comes to an automatic stop.

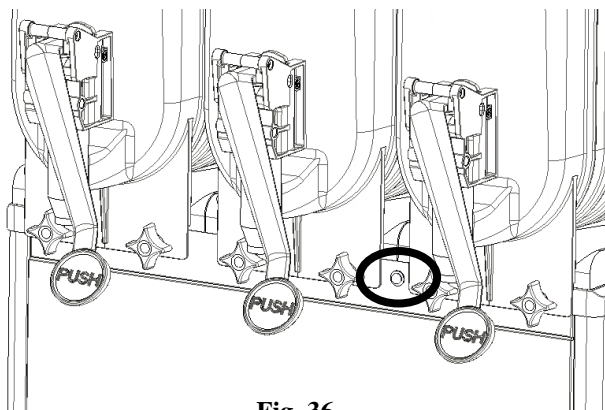

Fig. 36

Proceed as follows:

- Disconnect the machine from the power supply;
- If they are present, unscrew the filter fixing knobs;
- Remove the filter first by lifting it and second by pulling it outward as showed in fig.37;
- Carefully clean it from the dust and reassemble it;

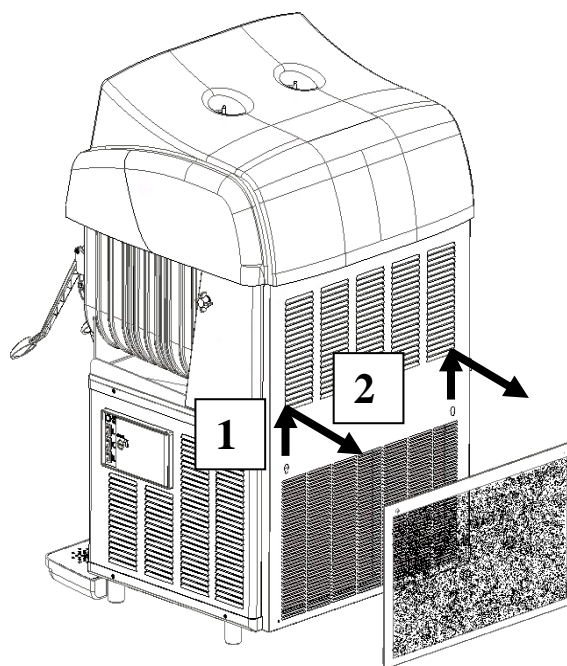

Fig. 37

Sometimes, if necessary, it could be necessary to remove the back panel and clean the condenser with a brush (fig.38).

**You are reminded that all the operations described above must be carried out with the machine switched off and the power cable disconnected.**

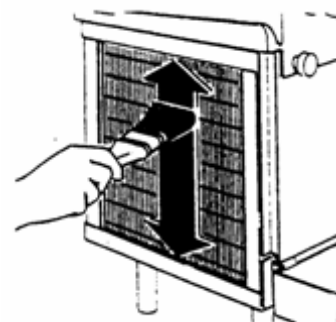

Fig. 38

## **INSUFFICIENT AIR FLOW ALARM**

To protect the entire cooling system, the ice slush drinks maker is fitted with an electronic system which issues a luminous warning signal in the event of insufficient ventilation or if the condenser filter is clogged with dust.

### **"FILTER CLEANING" Alarm**

A filter cleaning alarm will activate when the unit is running hot due to insufficient internal air circulation. When this occurs the frontal LED starts blinking (one second ON and one second OFF) to alert the operator of this condition.

The refrigerating system is still working normally, to determine the condition that caused the alarm and switch it off, see list of conditions below:

- Condition: The filter is dirty and needs to be cleaned.  
Corrective Action: Clean and replace filter following instructions.
- Condition: The unit is positioned too close to a wall or other object restricting air flow and causing the machine to run at a higher temperature.  
Corrective Action: Reposition unit to maximize ventilation space.
- Condition: The filter is not properly installed.  
Corrective Action: Properly install filter.
- Condition: The unit has been installed near a heat source, such as a coffee machine, ice maker or cold beverage machine which expels hot air from its vents, causing the machine to run at a high temperature (installation near a heat source should be avoided)  
Corrective Action: Reposition unit to maximize ventilation space.

If the operator does not intervene when the signal is issued, restoring normal working conditions, the electronic system will stop the machine automatically.

### **"SYSTEM OVER TEMPERATURE" Alarm**

A system over temperature alarm will activate as a safety precaution when the unit has overheated to protect the compressor.

- The system automatically goes to "OFF" status where the compressor's operations is stopped, while augers will keep working to avoid forming ice blocks.
- When this occurs the frontal LED is switched ON without blinking to alert the operator of this condition.
- When this alarm activates, turn off all switches. Then determine the condition. (See "Filter Cleaning" Alarm Section for Conditions and Corrective Actions).

## SEAL MAINTENANCE

**SPINDLE BUSHING:** replace every 6 to 12 months depending on conditions of use and level of maintenance. Replacement should **ONLY** be done by a qualified service technician

- Remove the Rulon bushing using a flathead screwdriver as shown
- Insert the brass guide tool on the drive shaft and slip the bushing over the guide tool and firmly press into place.
- Using the special tool C and rubber mallet, gently seat the bushing into place as shown
- Lubricate the bell shaped seal and reassemble onto evaporator/auger shaft.

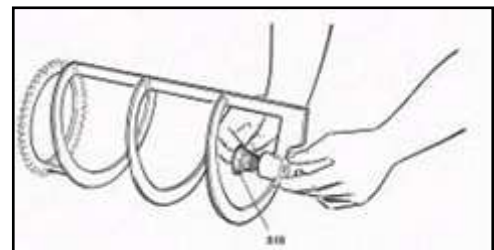
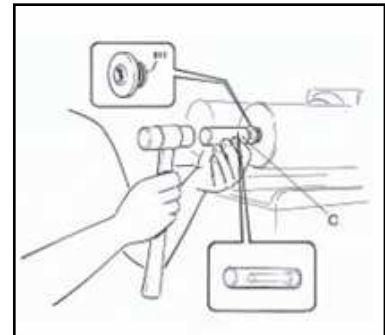
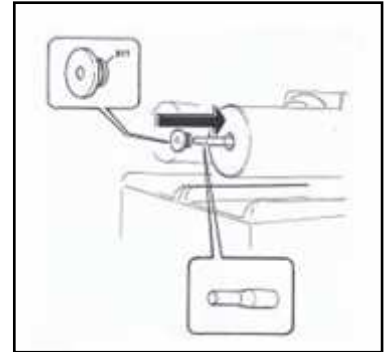
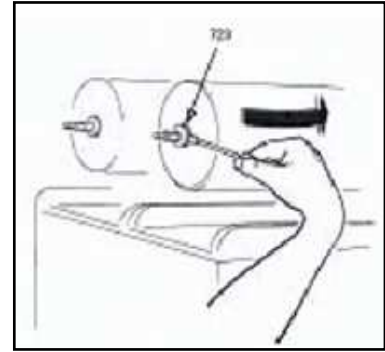

**BELL SHAPED SEAL:** replace every 1 to 6 months depending on conditions of use, level of maintenance and lubrication. This part should be lubricated during reassembly after every cleaning

**BOWL GASKET:** it's the red gasket located at the rear of the bowl, replace as necessary depending on conditions of use and level of maintenance; this part should be lubricated during the re-assembling after every cleaning.

**O-RING:** the dispense valve o-ring should be replaced every 6 to 12 months or as necessary when wear is apparent. Lubricate the o-ring each time they are replaced or the dispense handle is removed for cleaning

Release Date: 01/03/11

Publication Number: 1

Revision: 1

Pag. : 26/40

## AUTOFILL SYSTEM and PRESSURE MENAGEMENT

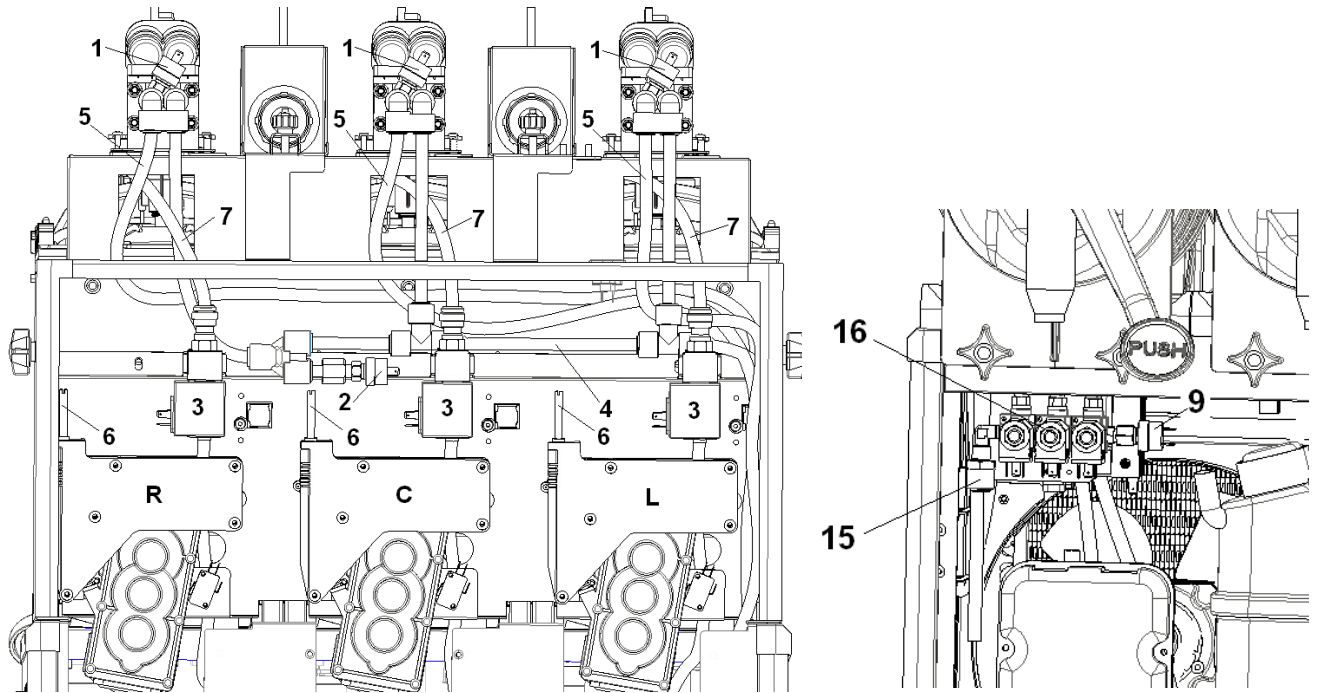

Fig. 39

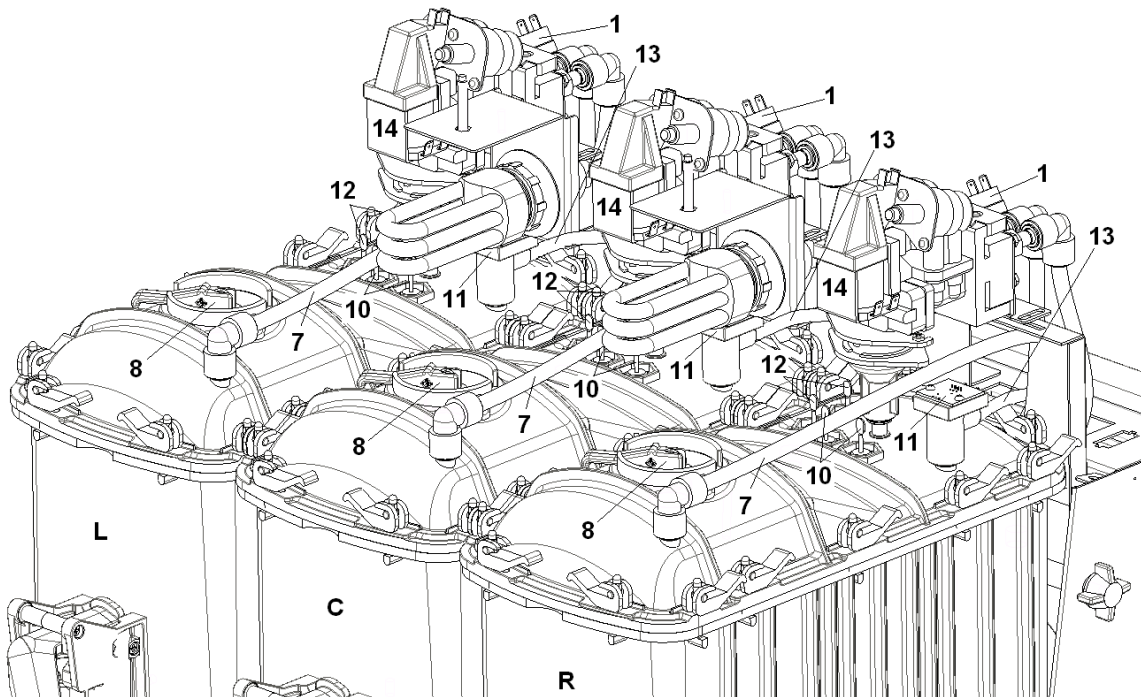

Fig. 40



DRINK SYSTEMS S.p.a.

COSTRUZIONE DISTRIBUTORI DI BEVANDE - MANUFACTURER OF BEVERAGE DISPENSER

S.P.M. Drink Systems S.p.a. - 41057 Spilamberto (Mo) Italy - Via Panaro, 2/b  
Tel. +39 059.789811 - Fax +39 059.781761

E-mail: info@spm-ice.it - Internet: www.spm-ice.it

Cod. Fisc. e Partita IVA 03195610369 - REA MO-366825

Cap. Soc. € 1000.000,00 i.v. - Foro Competente Modena - Cod. ident. CEE IT 03195610369

## VFCB-G2 Operator's Manual

### GENERAL FEATURES

The diagram shows the autofill system and pressure management system general features:

1. Syrup pressure switch (one for each bowl)
2. Soda pressure switch
3. CO2 total isolation discharge valve (one for each bowl)
4. Soda inlet line
5. Syrup inlet lines (one for each bowl)
6. Consistency adjustment screws (one for each bowl)
7. CO2 discharging line (one independent for each bowl)
8. Bowl mechanical relief valve
9. CO2 pressure switch
10. Overflow probes
11. Bowl pressure switch (one for each bowl)
12. Level control probes
13. CO2 inlet lines
14. Post mix valves
15. CO2 inlet connection
16. CO2 rail

### AUTOFILL SYSTEM

The three bowl will work independently.

### WATER/SYRUP REGULATION

It is possible to regulate the brix value only when both water and syrup are present and only when the control box is open; if all these conditions are respected, pushing one of the three switches means to dispense product from the related valve 14 in order to check the product brix value.

### LEVEL MANAGEMENT

The "level bowl" probes (12) function is to control and manage the product level in the bowl. They work **INDEPENDENTLY** one from the other (left bowl level probes work independently from right and central bowl level probes).

The level management is the same for each bowl and it is activated only when the control box is closed.

### FIRST FILLING PROCEDURE

When the control box door is closed, the switches are turned on and all the CO2, the syrup and the soda water are present along the circuit line, the augers are activated and the level probes are checked.

If the level probes 12 are uncovered, the post-mix charging valves 14 and the CO2 discharging ones 3 are activated at the same time until the level is reached.

When the probes are covered these two valves are closed.

If one of the three substances is not present (this condition is detected by pressure switches 1, 9 or 11), the bowl loading procedure will not be performed until the lack will be solved; at this moment the refill procedure will re-start automatically without any operator's intervention.

**Release Date: 01/03/11**

**Publication Number: 1**

**Revision: 1**

**Pag. : 28/40**

## SECURITY LEVEL PROBE (CUT OUT LEVEL PROBES) MANAGEMENT

The short level probes 10 control the product level in order to avoid any overflow risk if the "level bowl" probes are out of function (both of them or just one of them); if they are covered, the autofill system and the pressure control system are disabled.

If the security level probes have been reached, the three cover LED (1, 2 and 3 in figure 41) are switched ON without blinking; switch off the unit, disconnect the power cable and call the assistance in order to find the root cause and correct it.

## CO2 PRESSURE VALUE MANAGEMENT

The pressure management inside each bowl is totally independent; this control is active only after the first filling procedure.

In first filling condition the pressure inside the bowls is not checked until product reaches the "level bowl" probes inside each bowl. The pressure is controlled between 120 mbar (on) and 160 mbar (off) by the pressure switches 11 mounted on each bowl.

This pressure check is not performed during each filling phase.

If there is no more gas in the CO2 external tank the lack of CO2 is detected by the CO2 pressure switch 9 seated inside the machine frame; the **LED1 - 2 - 3 are blinking in succession** and it is necessary to turn the unit off, remove the empty CO2 tank and replace it with a new one. Once the tank has been replaced, the unit standard functioning will re-start automatically without any operator's intervention.

If, after 1 minute and 30 seconds, the pressure inside the bowls does not reach 160mbar, there is a leak of CO2; so the CO2 dispensing is interrupted in order to avoid the CO2 external tank run out; the **LED1 - 2 - 3 are all switched ON without blinking** and it is necessary to find out the origin of this lack.

## ALARMS

- a) LED1 blinking = left bowl out of syrup
- b) LED2 blinking = central bowl out of syrup
- c) LED3 blinking = right bowl out of syrup
- d) LED1 - 2 - 3 blinking all together = out of water
- e) LED1 - 2 - 3 blinking in succession = out of CO2
- f) LED1 - 2 - 3 all ON without blinking = security level probes reached or CO2 leak

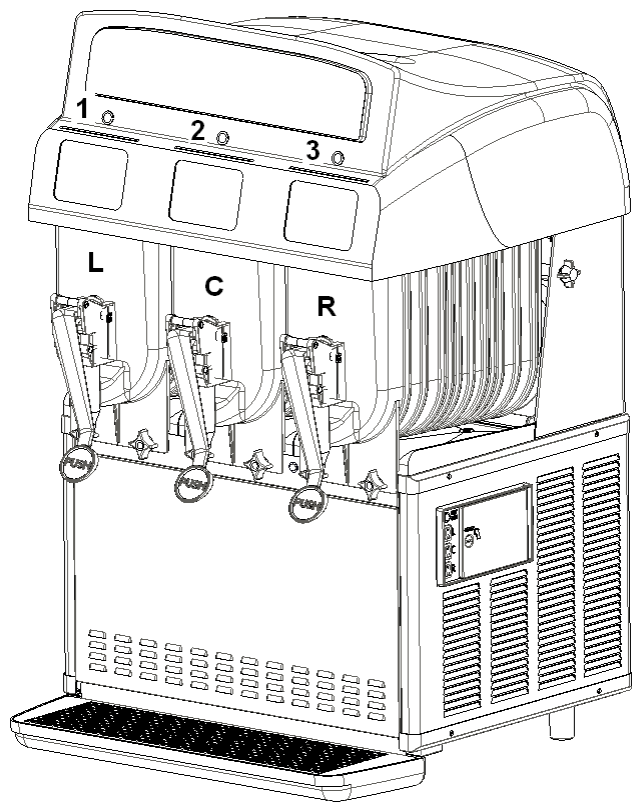
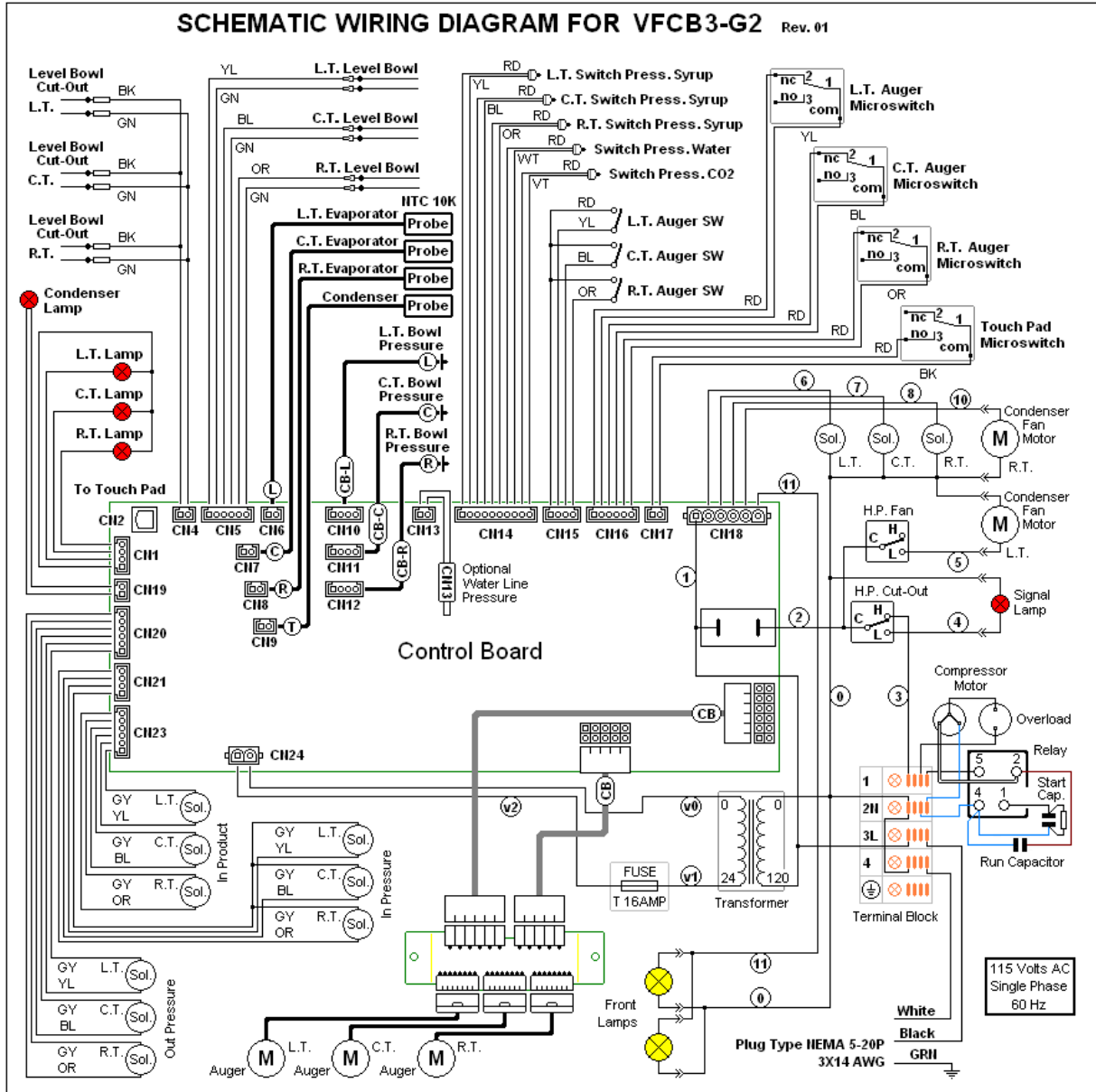

Fig. 41

# WIRING DIAGRAM





DRINK SYSTEMS s.p.a.

COSTRUZIONE DISTRIBUTORI DI BEVANDE - MANUFACTURER OF BEVERAGE DISPENSER

S.P.M. Drink Systems S.p.a. - 41057 Spilamberto (Mo) Italy - Via Panaro, 2/b

Tel. +39 059.789811 - Fax +39 059.781761

E-mail: [info@spm-ice.it](mailto:info@spm-ice.it) - Internet: [www.spm-ice.it](http://www.spm-ice.it)

Cod. Fisc. e Partita IVA 03195610369 - REA MO-366825

Cap. Soc. € 1000.000,00 i.v. - Foro Competente Modena - Cod. ident. CEE IT 03195610369

## VFCB-G2 Operator's Manual

**Release Date: 01/03/11**  
**Publication Number: 1**  
**Revision: 1**  
**Pag. : 31/40**



DRINK SYSTEMS s.p.a.

COSTRUZIONE DISTRIBUTORI DI BEVANDE - MANUFACTURER OF BEVERAGE DISPENSER

S.P.M. Drink Systems S.p.a. - 41057 Spilamberto (Mo) Italy - Via Panaro, 2/b

Tel. +39 059.789811 - Fax +39 059.781761

E-mail: [info@spm-ice.it](mailto:info@spm-ice.it) - Internet: [www.spm-ice.it](http://www.spm-ice.it)

Cod. Fisc. e Partita IVA 03195610369 - REA MO-366825

Cap. Soc. € 1000.000,00 i.v. - Foro Competente Modena - Cod. ident. CEE IT 03195610369

## VFCB-G2 Operator's Manual

**Release Date: 01/03/11**  
**Publication Number: 1**  
**Revision: 1**  
**Pag. : 32/40**

## TROUBLESHOOTING

**NOTE: The following procedures must be performed by a qualified service technician.**

### Problem

The "CONDENSER" LED is blinking or is ON without blinking

### Possible Cause

- The filter is dirty and needs to be cleaned
- The unit is positioned too close to a wall or other object restricting air flow and causing the machine to run at a higher temperature
- The filter is not properly installed
- The unit has been installed near a heat source, such as a coffee machine, ice maker or cold beverage machine which expels hot air from its vents, causing the machine to run at a high temperature. (Installation near a heat source should be avoid)

### Solution

- Clean and replace filter following instructions (Condenser Filter Cleaning)
- Reposition unit to maximize ventilation space (see installation figures)
- Properly install filter see
- Reposition unit to maximize ventilation space (see installation figures)

The machine does not cool, or cools only partially, but the compressor is running

- The space around the machine is inadequate for ventilation
- Freezer is in defrost
- The filter or the condenser are dirty and need to be cleaned
- Fan motor is not running
- Refrigerant is leaking

- Allow at least 8" (20cm) between the machine and anything next to it; keep away from heat sources
- Check the scheduler setup
- Remove the filter and clean it, if necessary, remove the rear panel and, using a brush or compressed air, clean the condenser
- Check the fan motor's electrical connections and, if disconnected, reconnect. If still not operating, replace the motor
- Locate the leak, eliminate it and recharge the system

The machine over-freezes, making the auger movement slow or stopped	<ul style="list-style-type: none"><li>• Electrical components of the compressor are not functioning</li><li>• Some electrical connections are not complete</li><li>• The compressor is malfunctioning</li><li>• The product brix is too low</li><li>• The screw setting for the product consistency control system is set too far toward the "+" position</li><li>• The consistency micro-switch arm is bent away from the gear motor and prevents contact</li><li>• The level of the product in the bowl is too low</li></ul>	<ul style="list-style-type: none"><li>• Replace the malfunctioning components</li><li>• Check the contacts and correct those that are incomplete</li><li>• Replace the compressor</li><li>• Check the product brix and correct</li><li>• Reset the screw toward the "-" position to produce a thinner consistency product</li><li>• Using pliers, straighten the limit switch arm</li><li>• Add more product or turn the refrigeration "Off"</li></ul>
The machine is noisy	<ul style="list-style-type: none"><li>• The fan motor blades are hitting internal components</li></ul>	<ul style="list-style-type: none"><li>• Check and correct</li></ul>
The bowl switches are "On" but the unit is not running.	<ul style="list-style-type: none"><li>• The 16A fuse on the secondary circuit is blown</li><li>• Some electrical connections are not complete</li><li>• One or more switches are malfunctioning</li></ul>	<ul style="list-style-type: none"><li>• Replace the fuse</li><li>• Check the contacts and correct the ones that are incomplete</li><li>• Replace the switch</li></ul>
<ul style="list-style-type: none"><li>• The red CUT OUT LED on the control panel is ON and the refrigerating system is not working</li></ul>	<ul style="list-style-type: none"><li>• The pressure cut-out switch has activated.</li></ul>	<ul style="list-style-type: none"><li>• Determine the condition. (See "Filter Cleaning" Alarm Section for Conditions and Corrective Actions) and manually switch on the pressure switch (red button under the unit)</li></ul>
<ul style="list-style-type: none"><li>• The control board display shows the message "COMMUNIC.ERROR! CHECK MAINBOARD"</li></ul>	<ul style="list-style-type: none"><li>• There is a communication problem between the control unit and the mainboard.</li></ul>	<ul style="list-style-type: none"><li>• Check and call assistance to solve.</li></ul>



DRINK SYSTEMS s.p.a.

COSTRUZIONE DISTRIBUTORI DI BEVANDE - MANUFACTURER OF BEVERAGE DISPENSER

S.P.M. Drink Systems S.p.a. - 41057 Spilamberto (Mo) Italy - Via Panaro, 2/b  
Tel. +39 059.789811 - Fax +39 059.781761

E-mail: info@spm-ice.it - Internet: www.spm-ice.it

Cod. Fisc. e Partita IVA 03195610369 - REA MO-366825

Cap. Soc. € 1000.000,00 i.v. - Foro Competente Modena - Cod. ident. CEE IT 03195610369

## VFCB-G2 Operator's Manual

Product is leaking out of the bowl	<ul style="list-style-type: none"><li>• One of the bowl seals is not in place</li></ul>	<ul style="list-style-type: none"><li>• Replace or reposition the seals</li></ul>
Product is leaking from the dispensing valve	<ul style="list-style-type: none"><li>• The dispensing valve has been incompletely or incorrectly replaced in its position</li><li>• The free movement of the dispensing valve is impeded</li><li>• Dispensing valve o-rings are damaged</li></ul>	<ul style="list-style-type: none"><li>• Reassemble and replace</li><li>• Clean and lubricate the valve and valve cylinder with the lubricant provided with the machine</li><li>• Replace the damaged/worn seal and check the condition of the driveshaft.</li></ul>
Product is flowing into drain tray through drainage tube	<ul style="list-style-type: none"><li>• The bell shaped "shaft" seal between the front of the cylinder and the auger hub has not been reinstalled properly</li><li>• The bell shaped "shaft" seal or the spindle bushing seal is damaged or worn</li></ul>	<ul style="list-style-type: none"><li>• Replace the seals</li><li>• Find the seal and put a new one back in place</li></ul>
The auger is not turning	<ul style="list-style-type: none"><li>• Switches not turned on</li><li>• Some electrical connections are not complete</li><li>• The gear motor(s) are malfunctioning</li></ul>	<ul style="list-style-type: none"><li>• Turn switches on</li><li>• Check the contacts and correct the ones that are incomplete</li><li>• Replace the gear motor(s)</li></ul>
The auger is creating noises as it rotates	<ul style="list-style-type: none"><li>• The large red bowl seal is not correctly in position causing the auger touching the cylinder during its rotation</li><li>• The product brix is too low</li><li>• The bell shaped "shaft" seal has been replaced without lubrication or is damaged</li></ul>	<ul style="list-style-type: none"><li>• Check and correct</li><li>• Check the product brix and correct</li><li>• Replace or clean and lubricate with the lubricant provided with the machine</li></ul>

	<ul style="list-style-type: none"> <li>• The auger has been incompletely or incorrectly reassembled (i.e. the auger's gear pins are not properly seated)</li> </ul>	<ul style="list-style-type: none"> <li>• Check and correct</li> </ul>
There is no light in the merchandising lid or rear merchandising panel	<ul style="list-style-type: none"> <li>• The light bulb is burnt out</li> <li>• The unit is working in defrost mode</li> </ul>	<ul style="list-style-type: none"> <li>• Replace</li> <li>• Check the unit scheduler setup</li> </ul>
The cover does not properly fit on the bowl	<ul style="list-style-type: none"> <li>• The bowl is incorrectly positioned</li> </ul>	<ul style="list-style-type: none"> <li>• Remove bowl and position properly</li> </ul>
Bowl not refilling	<ul style="list-style-type: none"> <li>• Out of syrup</li> <li>• Out of CO2</li> <li>• Out of soda water</li> <li>• Level probes already reached</li> <li>• Defective syrup/soda/CO2 pressure switch</li> <li>• Post-mix valve malfunctioning</li> <li>• Foam covering probes</li> </ul>	<ul style="list-style-type: none"> <li>• Replace</li> <li>• Replace</li> <li>• Replace</li> <li>• Check and replace</li> <li>• Check and replace</li> <li>• Wait</li> </ul>
CO2 leaking	<ul style="list-style-type: none"> <li>• Defective CO2 inlet valves</li> <li>• Defective CO2 shut off</li> <li>• Poor connection</li> </ul>	<ul style="list-style-type: none"> <li>• Replace</li> <li>• Replace</li> <li>• Repair leak</li> </ul>
One of three cover LED is blinking	<ul style="list-style-type: none"> <li>• The correspondent bowl is out of syrup</li> </ul>	<ul style="list-style-type: none"> <li>• Replace the BIB</li> </ul>
Three cover LED blinking all together	<ul style="list-style-type: none"> <li>• The unit is out of water</li> </ul>	<ul style="list-style-type: none"> <li>• Restore water supply</li> </ul>
Three cover LED blinking in succession	<ul style="list-style-type: none"> <li>• The unit is out of CO2</li> </ul>	<ul style="list-style-type: none"> <li>• Replace the CO2 tank</li> </ul>
Three cover LED all switched ON without blinking	<ul style="list-style-type: none"> <li>• Security level probes reached or CO2 leak</li> <li>• CO2 leak</li> </ul>	<ul style="list-style-type: none"> <li>• Find the root cause and resolve</li> <li>• Find the root cause and resolve</li> </ul>







### Conforme alla normativa RoHS

Questo apparecchio è conforme alla direttiva europea 2002/95/CE e successive modifiche per quanto riguarda la restrizione all'uso di sostanze pericolose nella produzione di apparecchiature elettriche ed elettroniche.



### Smaltimento

Ai sensi della direttiva RAEE 2002/96/CE e successiva modifica 2003/108/CE questa apparecchiatura viene contrassegnata con il seguente simbolo del contenitore di spazzatura con ruote barrato. " INFORMAZIONE AGLI UTENTI: Ai sensi dell'art. 13 del Decreto Legislativo 25 Luglio 2005 n. 151 - Attuazione delle Direttive 2002/95/CE e 2002/96/CE, relative alla riduzione dell'uso di sostanze pericolose nelle apparecchiature elettriche ed elettroniche, nonché allo smaltimento dei rifiuti. Il simbolo del cassonetto barrato indica che il prodotto, alla fine della sua vita utile, deve essere raccolto separatamente dagli altri rifiuti. L'utente deve conferire l'apparecchiatura giunta a fine vita ad idonei centri di raccolta differenziata dei rifiuti elettrici ed elettronici, oppure consegnarla al rivenditore al momento dell'acquisto di nuova apparecchiatura di tipo equivalente, in ragione di uno ad uno. L'adeguata raccolta differenziata per l'avvio successivo al trattamento e allo smaltimento ambientalmente compatibile contribuisce ad evitare possibili effetti negativi sull'ambiente e sulla salute e favorisce il reimpiego e il riciclo dei materiali di cui è composta l'apparecchiatura. Lo smaltimento abusivo del prodotto da parte dell'utente comporta l'applicazione delle sanzioni amministrative di cui al D.Lgs. n.22/1997."

**Release Date: 01/03/11**

**Publication Number: 1**

**Revision: 1**

**Pag. : 39/40**



DRINK SYSTEMS S.p.a.

COSTRUZIONE DISTRIBUTORI DI BEVANDE - MANUFACTURER OF BEVERAGE DISPENSER

S.P.M. Drink Systems S.p.a. - 41057 Spilamberto (Mo) Italy - Via Panaro, 2/b  
Tel. +39 059.789811 - Fax +39 059.781761

E-mail: [info@spm-ice.it](mailto:info@spm-ice.it) - Internet: [www.spm-ice.it](http://www.spm-ice.it)

Cod. Fisc. e Partita IVA 03195610369 - REA MO-366825

Cap. Soc. € 1000.000,00 i.v. - Foro Competente Modena - Cod. ident. CEE IT 03195610369

## VFCB-G2 Operator's Manual



DRINK SYSTEMS S.p.a.

COSTRUZIONE DISTRIBUTORI DI BEVANDE - MANUFACTURER OF BEVERAGE DISPENSER

S.P.M. Drink Systems S.p.a. - 41057 Spilamberto (Mo) Italy - Via Panaro, 2/b  
Tel. +39 059.789811 - Fax +39 059.781761

E-mail: [info@spm-ice.it](mailto:info@spm-ice.it) - Internet: [www.spm-ice.it](http://www.spm-ice.it)

Cod. Fisc. e Partita IVA 03195610369 - REA MO-366825

Cap. Soc. € 1000.000,00 i.v. - Foro Competente Modena - Cod. ident. CEE IT 03195610369



Company  
with certified quality  
management system  
UN EN ISO 9001

**Release Date: 01/03/11**

**Publication Number: 1**

**Revision: 1**

**Pag. : 40/40**