



G3 Power Unit

Full Height Screen



Machine Specifications

DIMENSIONS

Height with screen: 1270mm
Height without screen: 910
Width: 480mm
Depth (inc' drip tray): 670mm

CAPACITY

2 x 10 litres

NET WEIGHT

80Kg. empty

ELECTRICAL REQUIREMENTS

220 - 240vac
50hz
Single phase
3 wire
Single socket connection

SYRUP CONNECTION

Bag in Box

COUNTER TOP REQUIREMENTS

1 x 75mm hole at the back
for the python & power

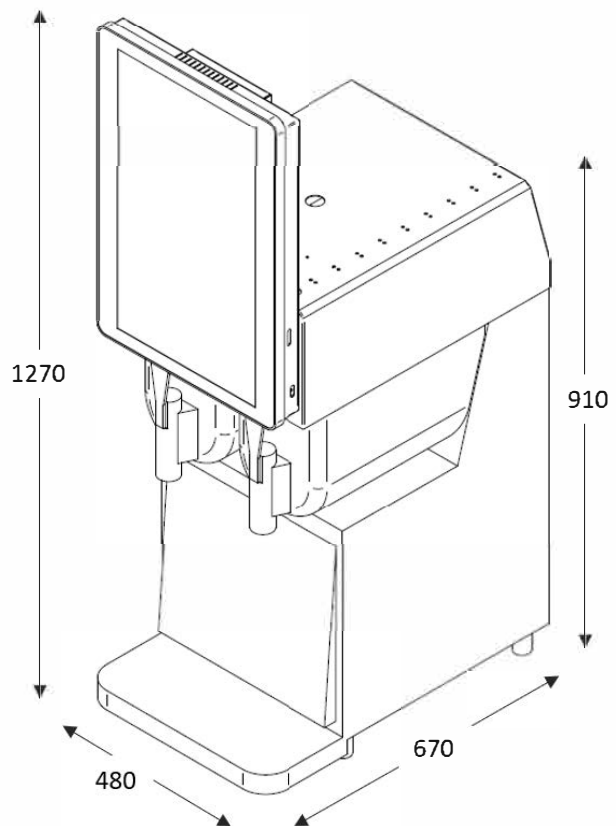



TECHNICAL DATA

PLATE DATA

The voltage and the frequency are indicated on the serial number plate, located behind the drip tray and the right hand side near the controls.

Machine	Bowl n°	Volt	Hertz	Ampere
VFCB POST MIX	2	220	50	11.8

IMPORTANT: This machine is intended for use at a maximum ambient temperature of 32°C (90°F).

Dimensions and weight:

VFCB2-G3

- Height with screen: 1270 mm
- Width: 480 mm
- Depth: 670 mm
- Weight: approx. 80 Kg

In the event of breakdown:

In most cases, any technical problem can be settled with slight interventions (please see the troubleshooting guide at the end of this manual); we therefore recommend you to carefully read this handbook before contacting the manufacturer or service centre.

Disposal



All the parts of the packaging must be kept beyond the range of children, as they might represent a potential safety/health risk.

Important

In respect of the environment, please dispose the packaging as illustrated.



This symbol:  means that the machine cannot be disposed as common waste. It must be handled in compliance with the provisions of European directive 2003/108/CE (Waste Electrical and Electronic Devices - WEEE) and the resulting national legislation, in order to prevent any potential damage to the environment and to create health risks.

In order to correctly dispose of the device, please contact the distributor from which you purchased it or our after-sales service.